

MUNKEBO NETHAULER TYPE SM/M-1-12VOLT

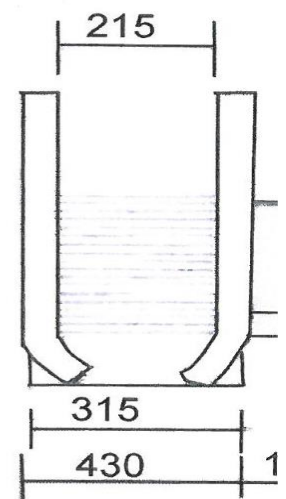
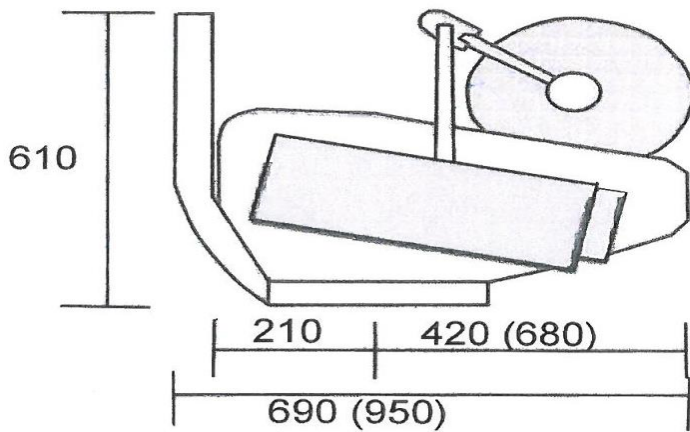

Specifications:

This type is standard fitted with 12 Volt electric motor, built-in adjustable control + front-stop-back, + and - the cables must be mounted on a 12 Volt battery.

Electric Motor: 12 Volts (Consumption Approx. 40-50 Amps per Hour).

Friction: 200 kg

Belt speed per minute: 45 m

Weight: 48 kg